



VYMPEL
GmbH



CONG Prima-2M

Dew point transducer



The **CONG Prima-2M dew point transducer** is an automatic condensation hygrometer designed to measure the water dew point and hydrocarbon condensation temperature of natural gas at preparation, transportation and distribution facilities.

Characteristics

Range of dew point temperature measurement, °C	Range I	-30 ... T ambient
	Range II	-60 ... T ambient
Accuracy limits for dew point measurements, °C	Accuracy class A	±0,5
	Accuracy class B	±1,0 in range -30...T ambient ±1,5 in range -60 ...-30
Range of hydrocarbon condensation temperature measurement, °C		-30 ... T ambient
Measurement cycle time, mins		5 ... 15
Maximum pressure of the target medium, bar, max		160/300
Explosion-proofing marking		II2G Ex d IIA T5 Gb (ATEX); 1 Ex d IIB T5 X (TPTC)
IP degree of protection		IP67

CONG Prima-2M can be configured for direct installation on the pipeline

Pipeline installation can be outfitted with a filtration module



Technical Data

Measurement range	Water/HC	-40 °C...+30 °C* $\Delta T \leq 60$ °C
Absolute error	Water/HC	± 0.5 °C...1.0 °C
Dew point measurement cycle duration		10...15 min
Sample gas volume flow rate		0.3...1 L/min
Ambient temperature		-10 °C...+50 °C
Pressure measurement range		≤ 160 bar**
Housing protection type		IP 56
Explosion-proof rating	ATEX: GOST R: TC TR EX:	Ex d IIA T5 1 Ex d IIB+H2 T5 1 Ex d IIB T5 X
Interface		RS 485 ModBus 4-20 mA
Dimensions		207 mm x 112 mm x 235 mm
Weight (without accessories)		6.5 kg

* Supplemental cooling is necessary when measuring dew points < -30° C

** Not including accessories (such as gas sample hoses)

Product features



- Fundamental and proven method of dew point measurement
- Measurement technology based on the reflectivity of a condensation mirror
- Lightweight and compact
- No separate control unit — control input by means of a magnetic key
- Intelligent mirror cleaning mode — the mirror's surface is scanned after each measurement cycle and cleaning is automatically based on the current condition of the mirror
- No calibration necessary
- No drift
- Greatest possible degree of flexibility thanks to three different deliverable versions and modular construction
- Intuitive operation
- Dew point registration system with two independent channels, thus providing a clear distinction between water and hydrocarbon dew points
- Data transfer interfaces
- Maintenance can be performed without interrupting pipeline gas flow
- Low maintenance requirements

Notes

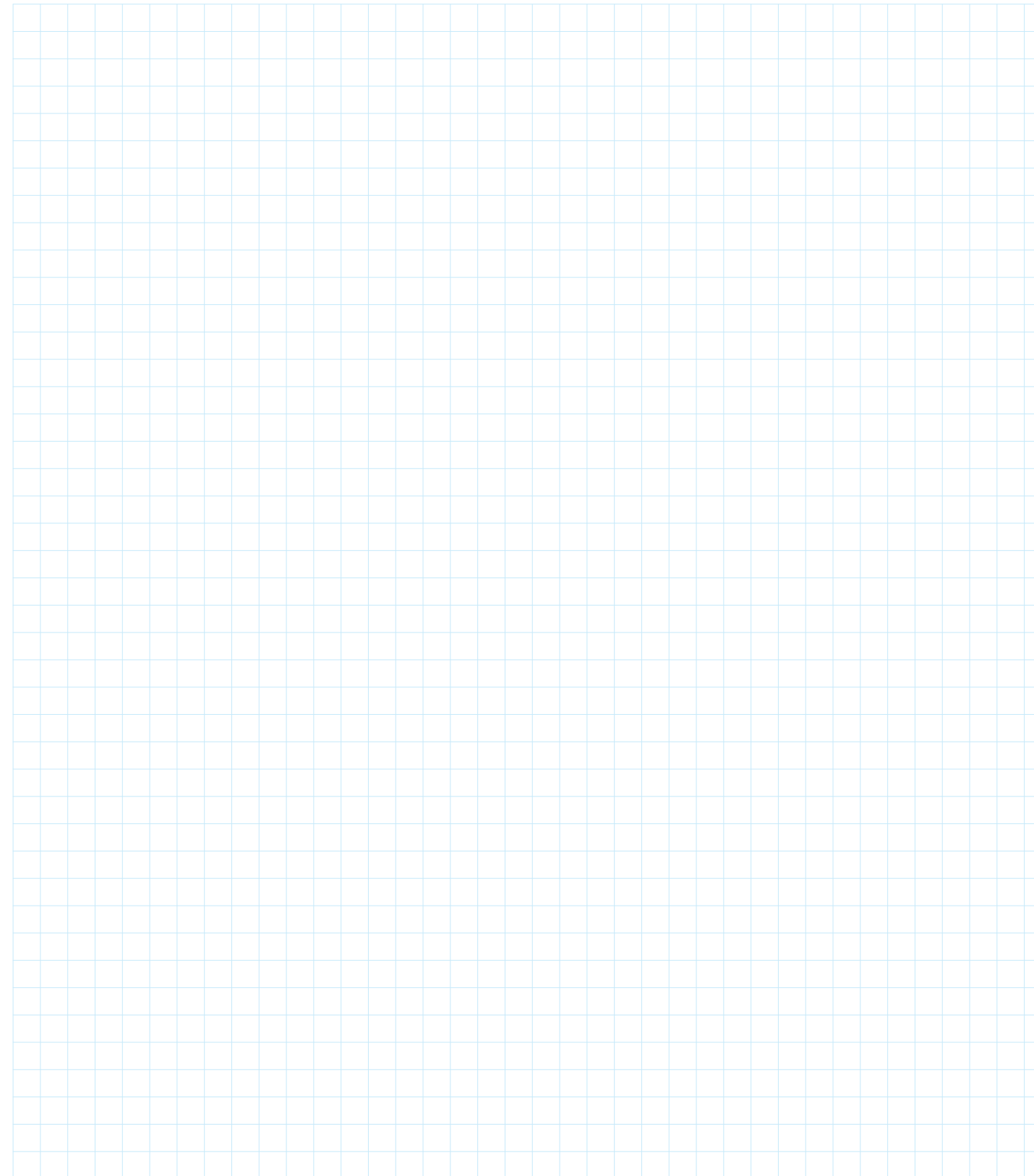

Please note: Product development and improvement are ongoing, therefore product data and specifications may be altered without prior notification.

VYMPEL GmbH

Bahnstr. 17 | 40212 Düsseldorf | Germany | phone: +49 211-21077-391 | fax: +49 211-21077-399 | e-mail: info@vympe.de

www.vympe.de

Cong Prima 2M



Cong Prima 2M

Dew point for everyone

The **Cong Prima 2M** is an automatic through-flow hygrometer. Moreover, it is the most compact and economical solution in the industry.

The concept for this dew point transducer (DPT) is based on the fundamental principle of direct measurement.

A condensation mirror is employed for the purpose of measuring the dew points of both water (dpW) and hydrocarbons (dpHC). The CP 2M establishes dew point by monitoring alterations in the mirror's reflectivity associated with the accumulation of condensates due to changes in temperature and pressure. Using laser interferometry, the analyzer can register a condensation film as thin as 10 nm.

The Cong Prima 2M can be set to automatically measure the dpW or dpHC, as desired. The unit can also be easily adapted to taking measurements for the purpose of monitoring operational processes.

The CP 2M's monobloc construction is comprised of a sensor cell, an electronic unit, and an explosion-proof housing. The analyzer can be fitted with either an analogue (4 – 20mA) or a digital (RS 485 – Modbus) data interface.

The robust design of the analyzer's measurement chamber corresponds to the strict requirements for a dew point measuring device in an aggressive gas environment. The unit is controlled by means of magnetic "buttons" that are operated using a special key (included with delivery).

The Cong Prima 2M dew point analyzer is available in three different versions, making it possible to perfectly tailor the unit to your individual requirements.

CP 2M – Measurement module (MM)

The measurement module version of the CP 2M is primarily intended for gas analysis in laboratory and industrial settings, where the gaseous mixture is characterized by a high degree of purity.

In addition, the design of the unit makes it suitable for mounting in already installed measurement systems as a dew point transducer.

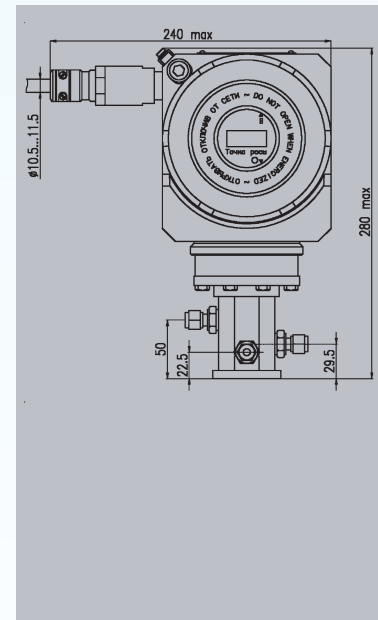

The CP2M is designed for use in systems that are based on the through-flow principle.

CP 2M – Pipeline module (PM)

Uncomplicated, fast, and direct is the motto here: the CP 2M measurement module is combined with an insertable sampling device. This insertable unit makes it possible to mount the analyzer directly onto the gas pipeline (min. \varnothing 200 mm).

The advantages of such a solution speak for themselves.

The pipeline module boasts a compact design and is ideal for installation sites that require a space-saving and attractive solution. This combined unit is equally well-suited to indoor (closed room) and outdoor applications.

This module is appropriate for installation at gas transport, gas reduction, and gas regulation facilities, as well as a variety of other facilities where the gas composition has no liquid impurities.

The insertable sampling device ensures that the gas sample is free from mechanical contaminants. The integrated shutoff valve allows the user to remove the analyzer unit without interrupting the gas flow in the pipeline.

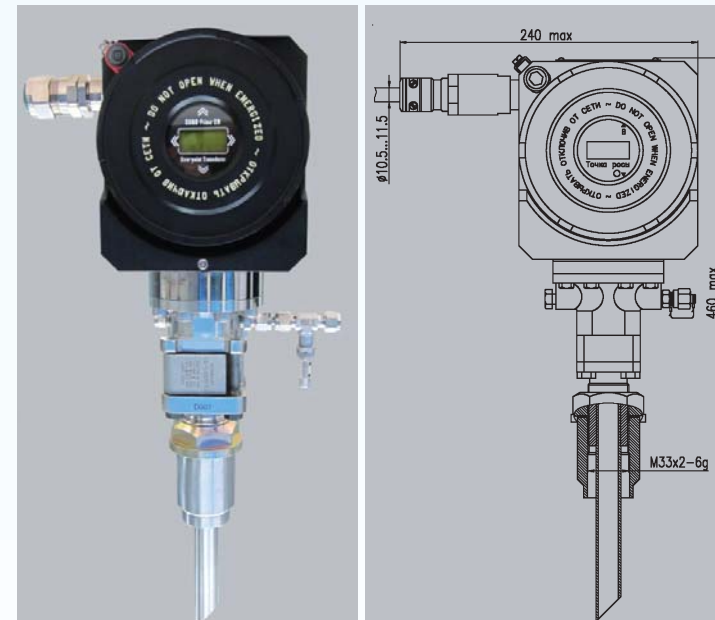

The CP2M is designed to be easily mounted directly on the pipeline.

SGA + CP 2M – Universal system (US)

Comprised of the Cong Prima 2M dew point analyzer and the SGA 003 gas preparation system, the innovative approach of this combined unit sets a whole new standard in the field of dew point measurement.

For the first time, one system provides a universal solution for all of the usual challenges faced in the gas industry in terms of accurate dew point measurement.

For example, a given pressure may be stipulated by law, contract or for some other reason. The SGA + CP 2M universal system makes it easy to take dew point measurements at virtually any pressure (including working pressure) up to 160 bar.

A number of patented new developments make a reliable analysis of the gas sample possible, even under the most difficult conditions in which mechanical and aerosol contaminants would have previously rendered dew point measurements all but useless. At the same time, this unit uses neither membrane filters nor any other elements that are subject to wear. Such components are a weak point in any system, due to the unpredictability of wear incurred

during operation. A clogged membrane, for example, can lead to distortions or even alterations of the gas sample's properties. With the SGA + CP 2M universal system, this issue is simply avoided.

This technology provides the foundation for our consistently high standards when it comes to providing you with reliable dew point measurement processes.

The underlying concept of the SGA is to make it possible for the dew point analyzer to easily measure the dew point of water (dpW) at the operating pressure and the dew point of hydrocarbons (dpHC) at reduced pressures – for example 27 bar.

In addition, in order to make the system easier for the operator to use, it offers preprogrammed modes for measuring the dew points of water and hydrocarbons.

Another feature of this solution is the system's modular construction. Among other things, this approach provides the user with the option of easily mounting and connecting a portable Hygrovision analyzer as a reference instrument.

Like to know what's going on in your gas sample? By installing a portable Hygrovision unit as a reference hygrometer, you will always be able to use its visualization system to see into the very heart of the measurement process. In this way you can gain a clear understanding of exactly what is taking place in the gas sample. The addition of a Hygrovision analyzer also makes possible continuous comparative measurements to confirm the dew point results of your CP 2M. Alternatively, it makes possible simultaneous measurement of the dew points of both water and hydrocarbons. The SGA system incorporates a foldout mounting arm and explosion protected gas connections for the easy integration of a Hygrovision unit into the gas delivery system. Thus the portable analyzer can be used for spot-checking or long-term reference. Naturally, the Hygrovision unit also provides for data transfer via Modbus RS-485 or IR-Port.

Due to its modular construction, the SGA + CP 2M system can, if necessary, be adjusted to meet constantly changing requirements. In this way it offers the greatest degree of flexibility while constantly maintaining the highest standards of accuracy and reliability



Notes

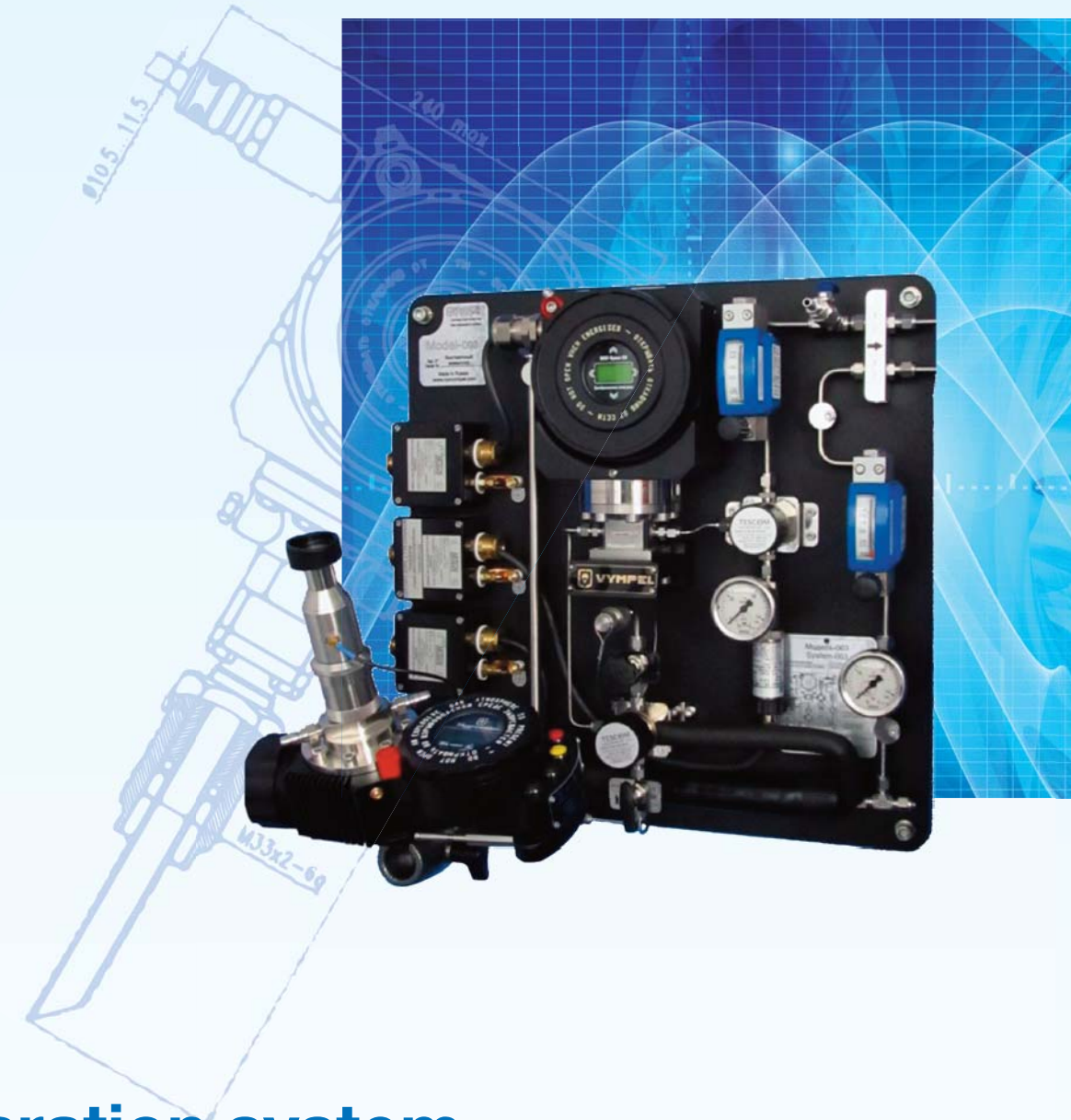
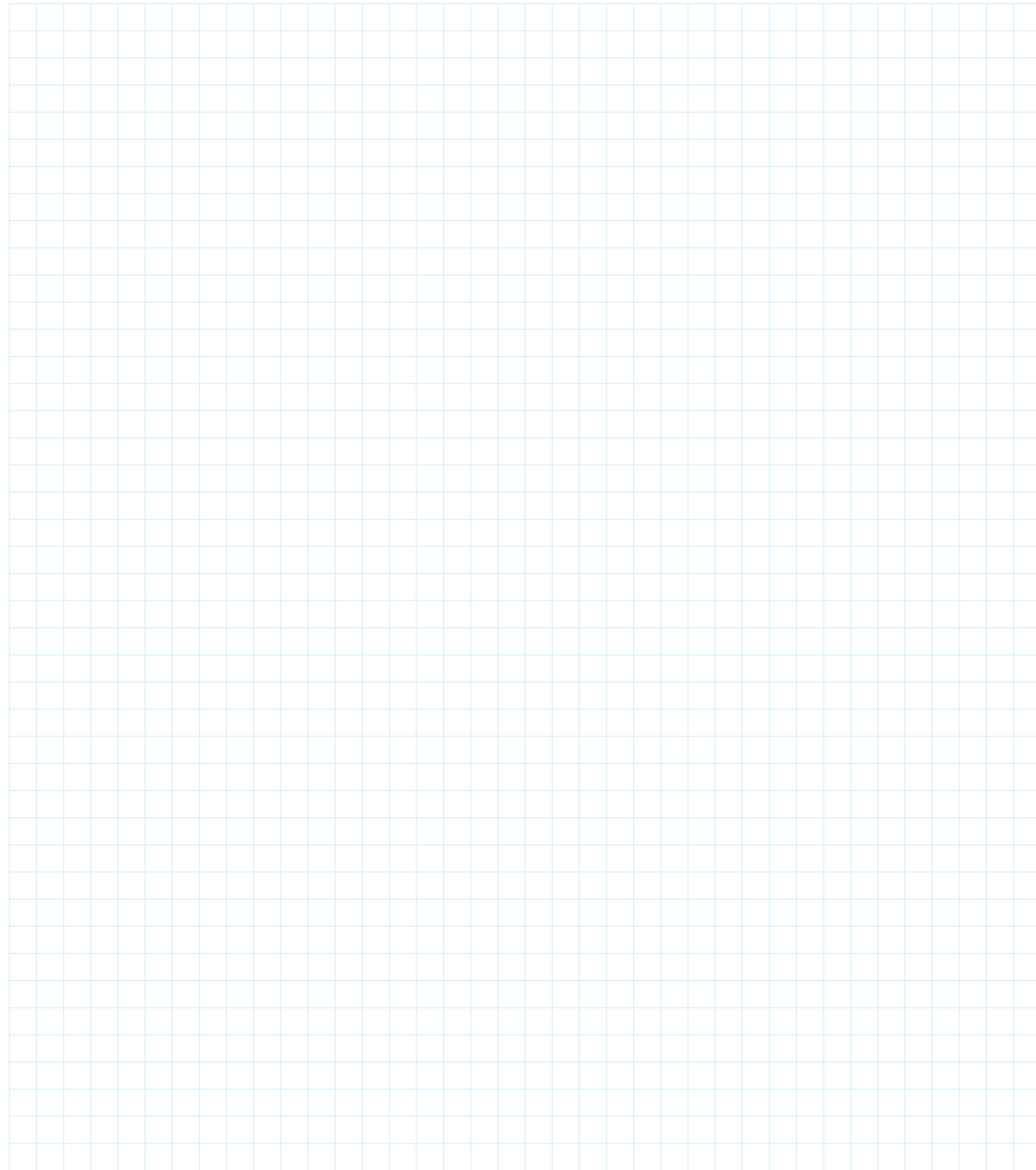

Gas preparation system SGA 003

Please note:

Product development and improvement are ongoing, therefore product data and specifications may be altered without prior notification.

VYMPEL GmbH

Bahnstr. 17 | 40212 Düsseldorf | Germany | phone: +49 211-21077-391 | fax: +49 211-21077-399 | e-mail: info@vympe.de

www.vympe.de



as preparation system SGA 003

Our System for your success

The SGA 003 gas preparation system is the newest product from Vympel.

This system is the result of intensive research and an innovative approach. The SGA 003 sets new standards in the field of gas preparation. Moreover, this system provides users with a range of new possibilities for modification.

The revolutionary principle of our patented new gravity filter – a key component of the SGA 003 — makes it possible to prepare gas samples without the use of any kind of membranes or cartridges. Such components are weak points in any system due to the unforeseeable consequences of normal wear and tear from continuous use.

Gas samples prepared by the SGA 003 are not subject to the problems presented by traditional systems, where gas sample conditions are compromised due to filters that are clogged or no longer intact. By contrast, SGA's filtration system is able to consistently deliver the highest quality gas sample. The SGA 003 is the first gas preparation system that offers the gas industry a universal solution for all of the typical problems that have an impact on dew point measurements.

This system is capable of preparing sample gas for dew point measurement at a variety of pressures; whether at operating pressure or in accordance with contractually or otherwise stipulated pressure requirements — up to 160 bar (Fig. 1). In order to make using the SGA 003 as straight forward as possible, we have equipped it with preset modes for both water and hydrocarbon dew point measurements (Fig. 2).

Another feature of this new gas preparation system is the SGA 003's innovative reference module. This element provides an easy connection point for a control hygrometer from the Hygrovision series. Now it is possible to check your equipment anytime you like. This gives you an unprecedented level of certainty in your dew point values by allowing you to check and, if desired, document the validity of your current measurement results quickly and without significant expense.

The concept of our system is based on one simple rule: to design the measurement process around the operator.

We believe that the measurement process should be neither complicated nor difficult, and should not require years of practice.

Through the use of components that require less skill to master and modular construction, we have continuously pursued the goal of producing equipment that is easy to install and operate and as user-friendly as possible.

Moreover, this system offers a great deal of flexibility. With the help of the preinstalled modes, the operator always has the option to quickly and easily reset the gas preparation system in response to varying measurement requirements. In this way he or she can be assured of achieving the best results.

Check out the SGA 003 and discover a whole new experience in taking dew point measurements.

Schematic drawing of the SGA 003

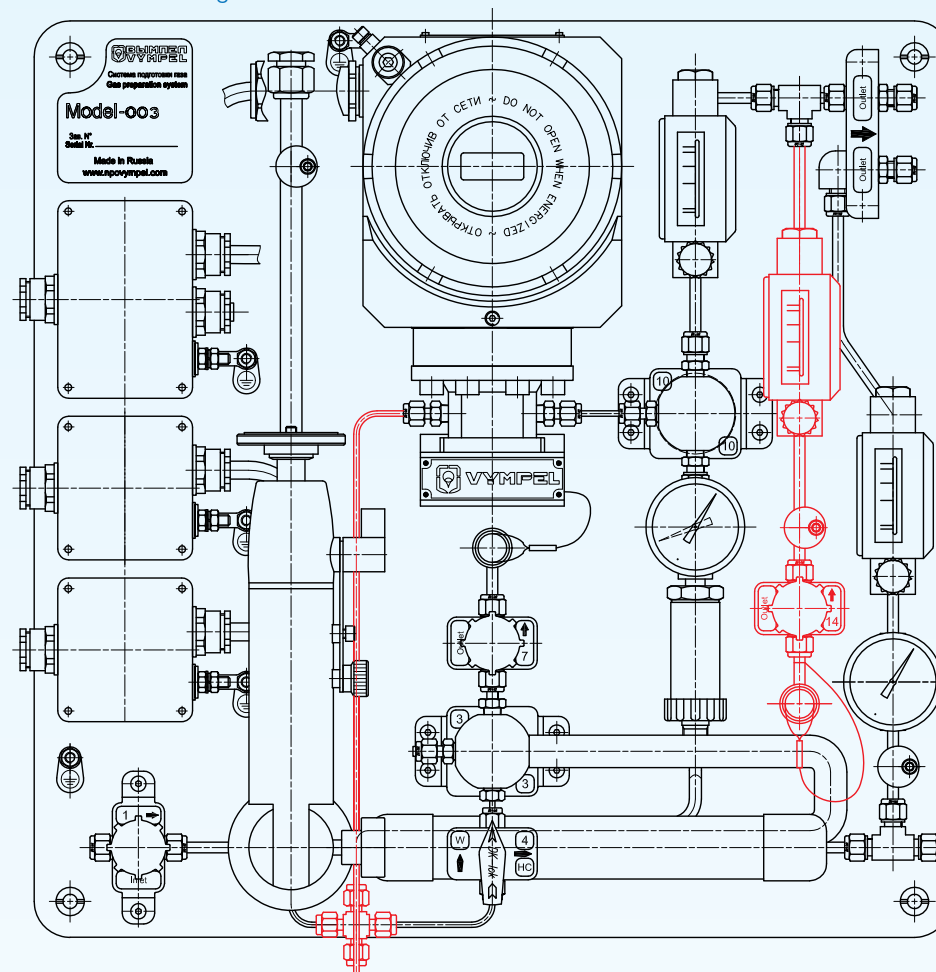

Product features

- Universal system for the measurement of water and hydrocarbon dew points
- No alteration of the gas sample
- No calculation necessary during the measurement process
- No calibration
- No drift
- Compact system (510 mm x 510 mm)
- All system components are designed to operate at pressures up to 160 bar
- Optional connection points for a reference instrument
- No additional gas release point required when a reference instrument is attached
- Environmentally aware design
- No filters that wear out
- Modular construction
- Variable pressure
- Minimal power consumption
- Option for connecting a portable Hygrovision BL for long-term operation

Optionally available module for connecting a second analyzer (high-pressure venting module) as a reference device or for simultaneous monitoring of the water and hydrocarbon dew points (dpW and dpHC module)



Technical Data

Dimensions	510 mm x 510 mm x 172 mm	
Weight	25 kg	
Sample gas flow rate	Measurement system	0.3...1 L/min
	Bypass system	max. 8 L/min
Pressure range	≤ 160 bar*	
Ambient temperature	- 10 °C...+50 °C	
Data output port	SGA 003	4 – 20 mA (Wika)
	Cong Prima 2M	4 – 20 mA Modbus / RS 485

* Does not apply to accessories

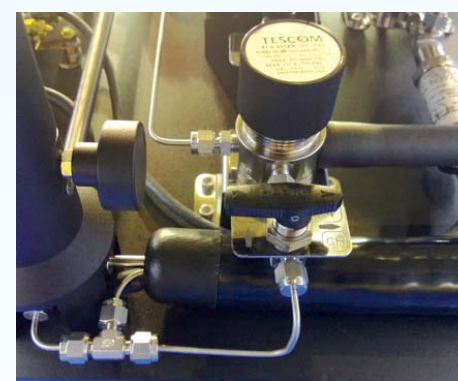

Fig. 1
Customize measurement processes by adjusting the measurement parameters

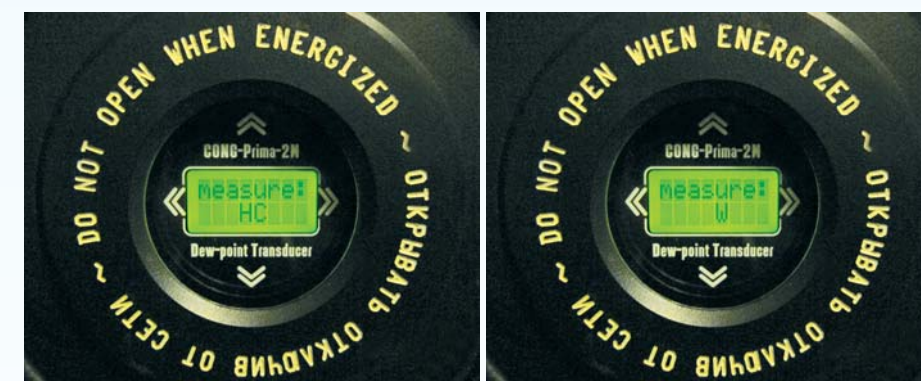

Fig. 2
Simple activation and switching of modes by means of a magnetic key



VYMPEL
GmbH



Service Unit



Service Unit is the additional unit of data processing and transmission of values of gas quality's indicators which is designed for extension of interfaces of dew point analyzers, e. g. CONG Prima-2M.

Features

- Moisture content calculations (g/m³, ppm)
- Recalculation of water dew point temperature to the requested pressure
- Automatic collection of gas quality indicators and CP2M working parameters
- 5 signal Alarm type outputs
- Possibility of installing GPS/GPRS module for the remote servicing:
 - Software upgrades
 - Adaptation of measurement algorithm
 - Hydrocarbon auto calibration
 - Maintenance

Specifications

Communication interfaces	RS-485
	Ethernet
	4 ... 20 mA (active)
	HART
	USB
Data storage, years	1
Power supply of analog signals 4 ... 20 mA	From built-in power source
IP degree of protection	IP68
Supply voltage, V	20 ... 27
Operating temperature, °C	0 ... +50
Dimensions, mm	191 x 125 x 60
Weight, kg	1

Notes



Pressure Reduction Module DRM 001

Please note:
Product development and improvement are ongoing, therefore product data and specifications may be altered without prior notification.

Pressure Reduction Module DRM 001

Plug & Play

We developed the **DRM** as a comprehensive support module for our revolutionary Hygrovision BL dew point analyzer.

Once you've worked with the BL you'll probably wonder how you ever got along without it! Thanks to its convenient size and intuitive operation, this analyzer is ideal for taking dew point readings at many different measurement points.

But we know, in the real world the rudimentary nature of connection fixtures in the field often makes the measuring process rather difficult and places limitations on the flexibility of this state-of-the-art portable analyzer.

It was a desire to overcome this challenge that inspired Vympel's engineers to develop the DRM. This module serves as a permanently installed docking station for the Hygrovision BL. Once the DRM is in place, the portable analyzer can be securely mounted and connected in just a few quick steps, without the need of extra tools or equipment – even in hazardous areas.

And unlike almost all of our competitors' units, the BL can measure the dew points of both water and hydrocarbons. Considering that the optimal measurement conditions for these two values are not the same, a docking station for the BL needs to be able to accommodate these differences – and that's exactly what we've designed the DRM to do.

For example, the water dew point is usually measured at operating pressure, whereas the hydrocarbon dew point is more and more often measured at around 27 bar. This pressure is known as the cricondentherm, and it corresponds to the highest temperature at which hydrocarbons will condense. Taking hydrocarbon dew point measurements at the cricondentherm provides the most reliable and accurate results; therefore it is increasingly being stipulated in contractual agreements.

With the DRM, changing from one measurement pressure mode to another is a matter of a few simple adjustments.

All-in-all, the combination of the DRM docking station and the Hygrovision BL makes it easier than ever to take dew point measurements in the field.

And should there be a desire to monitor the dew point for an extended period – overnight, for example – the Hygrovision BL can be plugged into the DRM's onboard power unit. As a result, the portable BL can function as an independent automatic online analyzer.

Thanks to its compact design, the DRM is ideally suited to installation at a range of different measurement points in a gas distribution system. And perhaps the most attractive feature of all – from the technician's point of view, at least – is the DRM's convenient foldout mounting arm. This supports the analyzer and positions it perfectly for easy operation.

The DRM is a straightforward, user-friendly solution that takes the stress out of taking dew point measurements under almost any field conditions.

Technical Data:

Dimensions	510 mm x 300 mm x 324 mm	
Weight	9.5 kg (without analyzer)	
Sample gas flow rate	Measurement line	0.3...1 L/min
	Bypass line	max. 8 L/min
Measurement pressure	≤ 160 bar*	
Ambient temperature	– 10 °C...+50 °C	
Data port	Hygrovision BL	ModBus / RS 485 IR-Port

* Does not apply to accessories

Product Features:

- Universal system for sample gas pressure regulation
- Integrated mounting platform for Hygrovision BL dew point analyzer
- No alteration of the gas sample
- Quick-connect couplers
- Modular construction
- Onboard power supply
- Built-in gas line heater to ensure correct sample gas temperature
- Simple to operate
- No calibration required
- No measurement drift
- Compact design
- All components are designed to operate at pressures up to 160 bar
- Low energy consumption
- Adjustable pressure (0.3...35 bar)

